

APPENDIX A**Subsurface Operations****Section 1. General****A-1. Type facilities.**

- a. This appendix explains how guerrillas may use natural caves or construct underground facilities in the course of their operations. These may be used for command and control centers, logistical staging areas, hospitals, or even fortifications.
- b. The larger underground facilities may be complex. Caves may have many large chambers connected by passageways, while tunnel systems may have many large rooms joined by interconnecting tunnels. Underground facilities may be wired for electricity and communications and may even have pumping stations for supplying air to lower levels.

A-2. Tunnel uses.

Tunnels may be dug with zigzags and sumps to lessen the effects of small arms fire, explosives, and gas inside them. Some tunnels and rooms, or passageways and chambers, may contain concealed exits to allow guerrillas to hide or escape if the complex or cave is penetrated while others may be booby-trapped to kill intruders. Tunnels and caves are difficult to detect from the air or ground, and their construction may make them impossible to destroy with conventional ammunition. Tunnel entrances are normally covered by fire from another point in the complex.

- a. Guerrillas may use tunnels in penetration operations to gain access to restricted areas. In built-up areas they may infiltrate through sewers, or tunnel from the basement of a nearby building, or subway tunnel, or sewer to their target. When they are below the target, they may either construct an exit and penetrate the target from below or fill the tunnel with explosives and blow up the target.
- b. Tunnels may also be dug in the basements of safehouses for use as escape routes if a house is compromised.
- c. Tunnels are used for approach and escape. They are used to obtain access to caves and underground bunkers for use as firing positions and protection against indirect fires. They are also used as a common method of storing food and materials in underground caches. Some tunnel complexes are large enough to house underground hospitals and base camps.

Section II. Tunneling

A-3. Categories.

Tunnels vary from the simple to the complex. They are categorized as hiding holes, access and escape routes, underground base areas, fortified base camps, and bunkers.

- a. **Hiding holes.** There are three basic types of holes used by guerrillas. They are classified more by their location than by their construction. Methods of construction and dimensions can be expected to vary, depending on the area of operations.
 - (1) **Bamboo hole.** This is easily and quickly camouflaged (Figure A-1). The entrances to the holes differ as do the techniques of camouflage. Most of the entrances are within the edge of a bamboo clump or dense thicket or just outside the edge. The hole cover, or trapdoor, contains camouflage material. Some have pieces of cut bamboo or other vegetation affixed to the top of the door. The edges of the door fit snugly into the structure of the entrance. Other entrances may be covered by spreading materials over them.

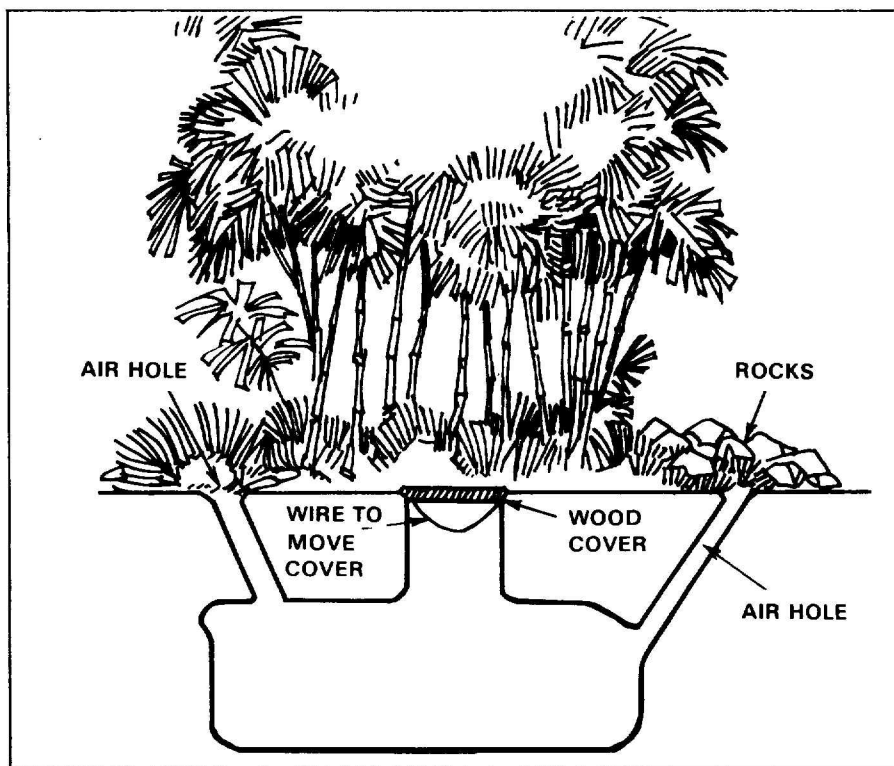

Figure A-1. Under bamboo hole.

(2) Air hole.

- (a) Another characteristic common to small tunnels is the air hole, which is normally made from a hollow piece of bamboo or pipe 3 to 4 inches in diameter and inserted into the tunnel and camouflaged on the surface.
- (b) The air hole is the only telltale indicator in a beach hole or tunnel. It differs from the bamboo hole in that it is constructed in sand or dirt and constructed from cut timbers (Figure A-2). It does not depend on roots to add rigidity to the roof. The entrance is hard to locate as it is often buried under a foot of loose sand or dirt; however, it can be found by first finding the breathing tubes. Some air holes are a continuation of the supports that hold up local buildings. Other air holes may be exposed by pulling up plants that grow nearby.

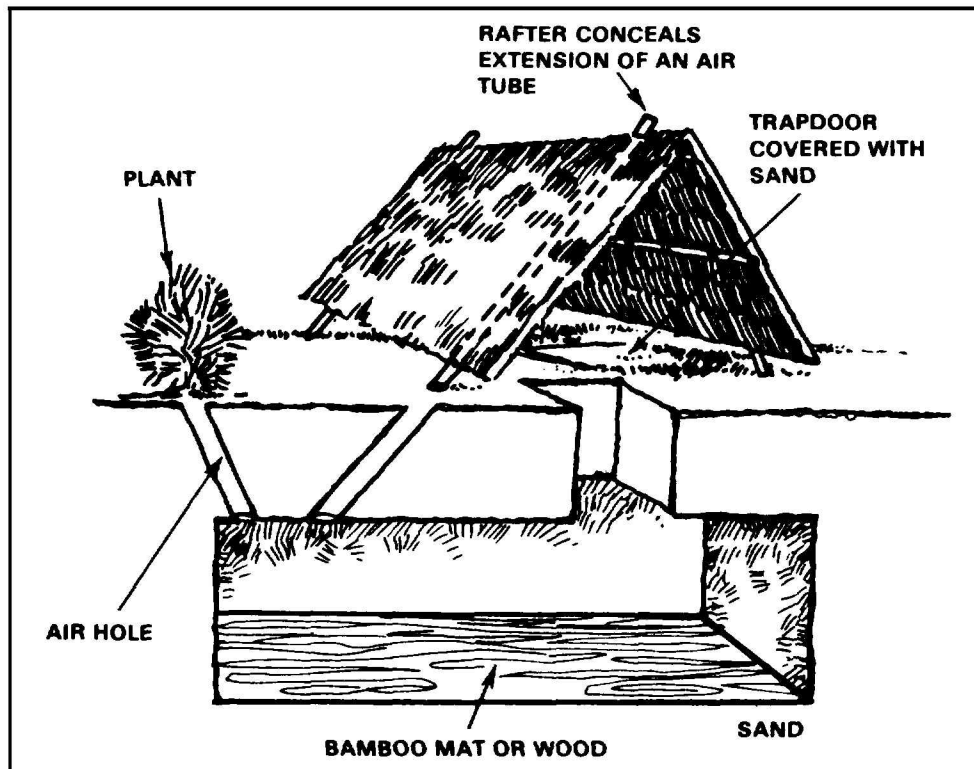

Figure A-2. Beach hole.

- (3) **Water entrance hole.** This hole or tunnel (Figure A-3) is located near a small stream or beside an old bomb crater filled with water. These holes have no door and depend on natural growth to hide the entrance. Sometimes the entrance is completely submerged.

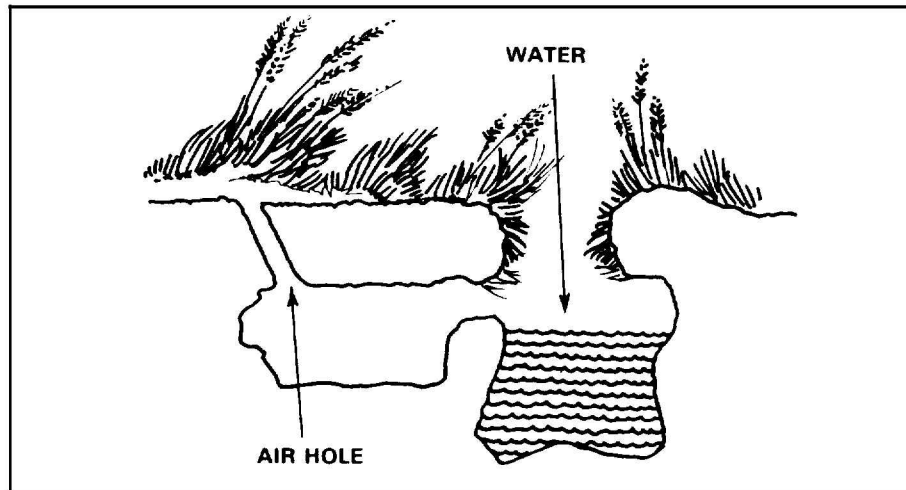

Figure A-3. Water entrance hole.

- b. **Access and escape routes.** Guerrillas use tunnels to infiltrate or exfiltrate an area. They may lead to villages, roads, or highly fortified bunker systems (Figure A-4).

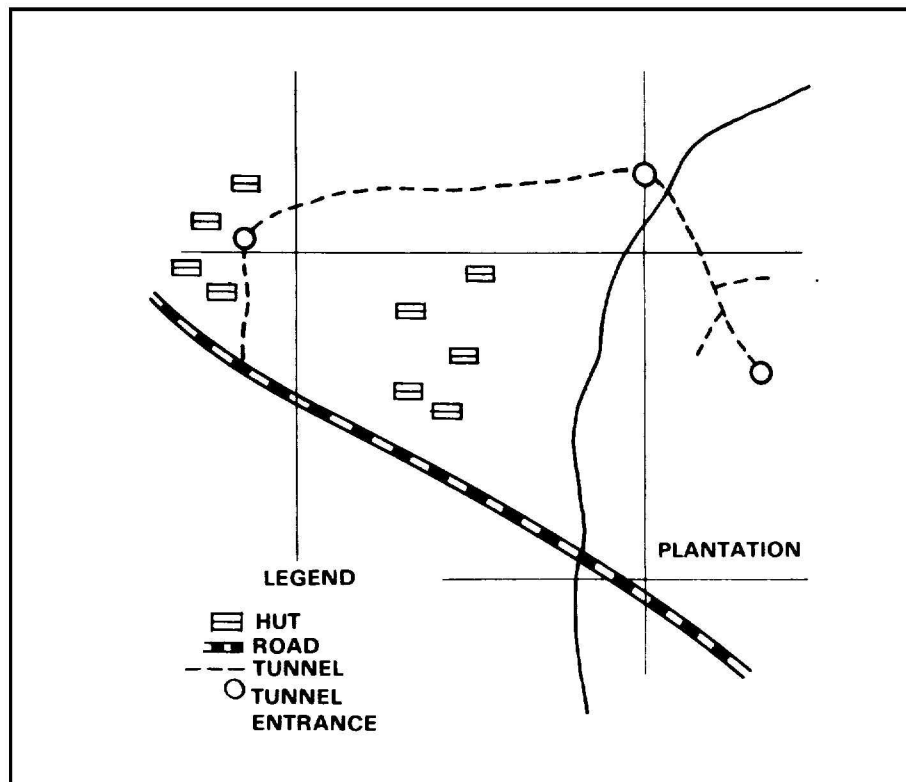

Figure A-4. Access and escape routes.

- c. **Base area.** This may house a command post, ordnance shop, or hospital. This type of tunnel system is not-as common as the ones found in a fortified village or used as access or escape routes. It is normally deep in guerrilla-controlled areas. This type of tunnel complex may have several rooms, such as a 4- by 6-foot area or a large 10-foot-square area with a 15-foot ceiling. They may also include electric lighting or other comfort features (Figure A-5).

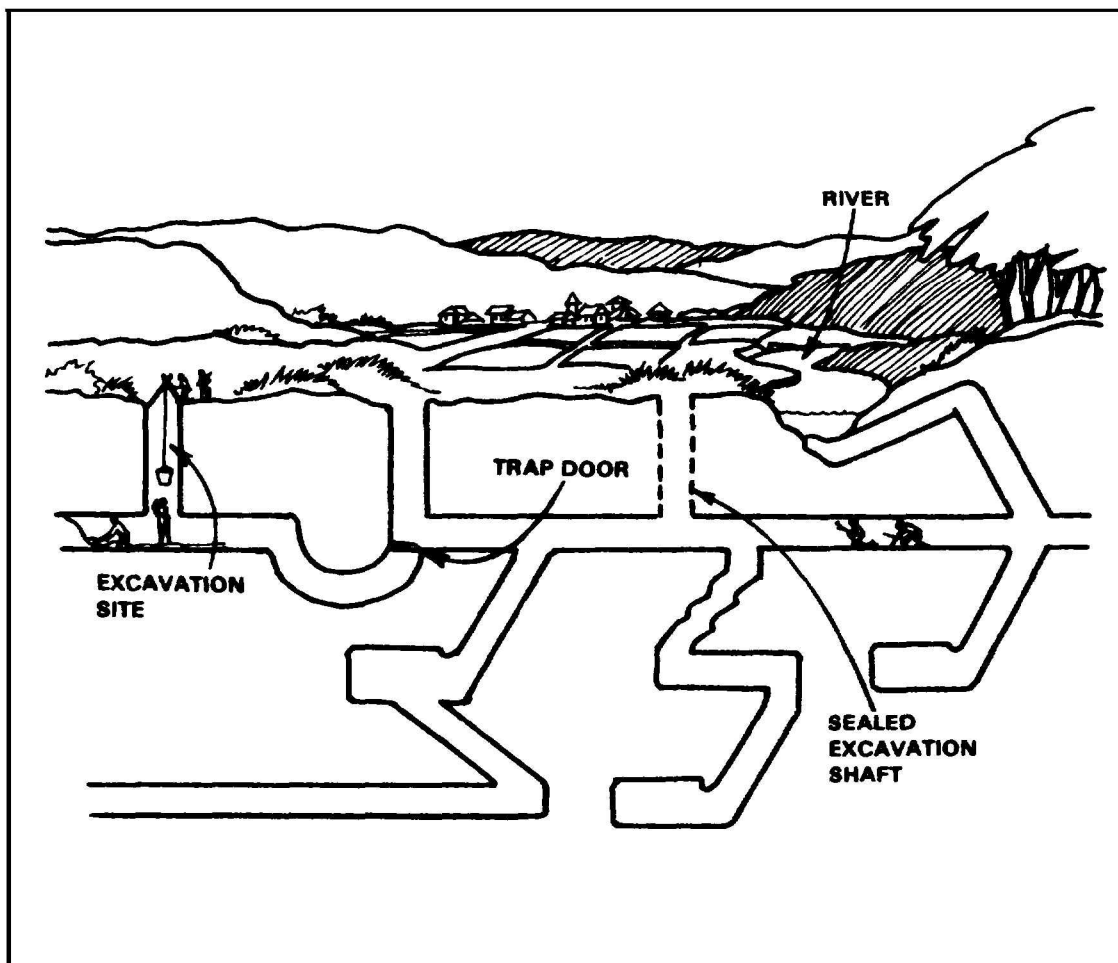

Figure A-5. Underground base area.

- d. **Base camps.** These are usually fortified positions. They may consist of a central bunker, 18 inches above ground, and tunnels 100 to 150 meters long, connecting outer bunkers to the central bunker. All bunkers have overhead cover and camouflaged firing apertures. They are positioned to provide mutual support and deny observation of the entire complex from any one location on the ground (Figure A-6).

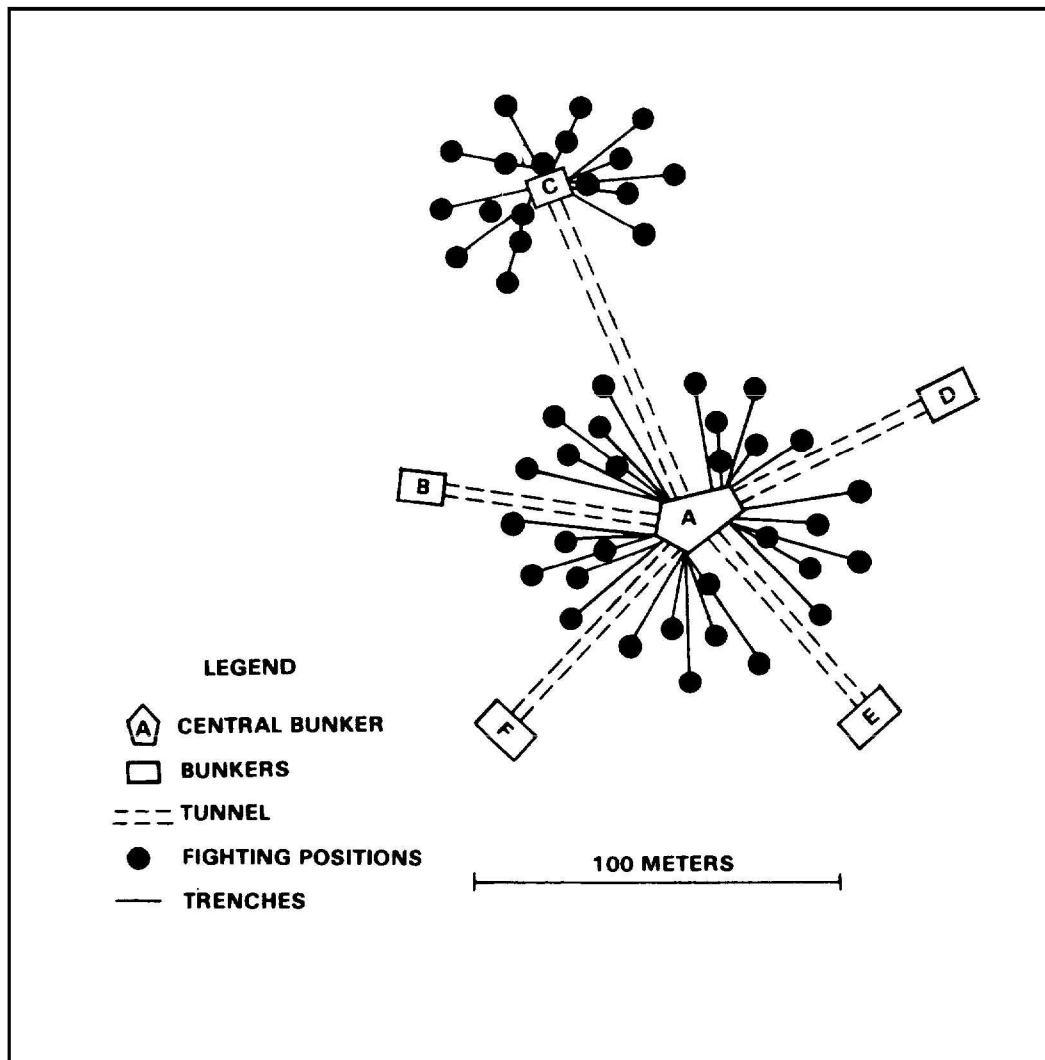

Figure A-6. Fortified base camps.

- e. **Bunkers.** Entrances are often in a house under a bed or table, and have an outside exit. In many cases, bunkers are constructed with walls up to 3 feet thick. The floor is below ground level. The roof is normally constructed of logs covered with dirt, mud, or rock from 3 to 6 feet thick. Sometimes, small logs (driven 3 to 6 feet into the ground and extending upward to roof level) serve to reinforce the walls. In some cases, the bunker maybe constructed entirely of concrete. Most often, bunkers have one overt entrance and one or more covert exits. The primary use of bunkers is to provide cover and concealment. Firing apertures are just above ground (Figure A-7).

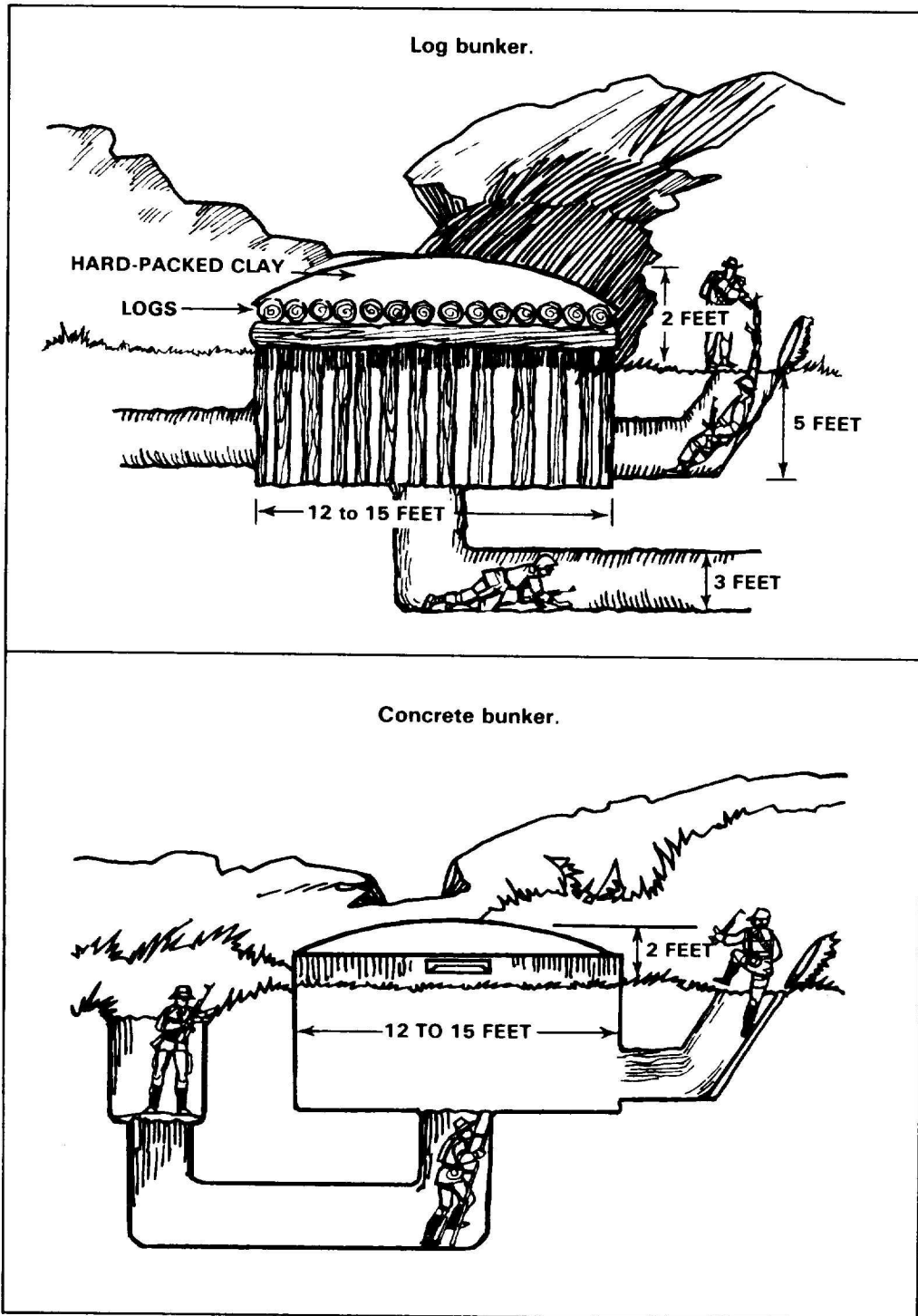

Figure A-7. Bunkers.

A-4. Construction methods.

- a. One feature common to almost all tunnel complexes is the method of excavation. The laborers are divided into a number of work units and assigned tunnel sections. The units are placed approximately 20 meters along the axis of the planned tunnel. Each unit then digs a well or shaft to the desired depth where a working area is enlarged. From this point, the units begin digging toward each other. As the tunnel grows, the workers are formed in a line to pass the soil out the excavation shaft. The soil is spread evenly over the ground or a road, or under the forest canopy to prevent detection. Once the main tunnel has been excavated, the shaft is filled and camouflaged.
- b. As the tunnel becomes more extensive, lower levels may be constructed to provide additional room and better protection. The degree of sophistication is dependent upon the purpose of the tunnel and frequency of its use. Most of the tunnels constructed by guerrilla forces are hiding places or escape routes; therefore, they may be extensive in length, but not complex in design.
- c. Whether their construction is complex or not, care is taken to provide security throughout the tunnels. False corridors are constructed, as are trapdoors and false walls. A U-shaped design is often formed to give the impression that the corridor is a deadend when actually a trapdoor leads to the way out.
- d. Most tunnel systems require substantial planning before actual construction. The systems are never haphazard. The tunnel is reinforced by reveting or other means. One common method used to reinforce tunnels is to coat walls with mud 3 to 6 inches thick and build fires throughout the system to bake the mud, turning it into a ceramic texture.
- e. Tunnel systems are usually not constructed in a straight line. They will follow a zigzag or serpentine course. This type of construction is used to protect the occupants from small arms fire in the event that tunnel systems are detected and breached.
- f. Tools for digging are simple. A bucket and pick or shovel are the main tools. Common methods of illumination include carbide lamps, flashlights, candles, and in larger complexes, small, fuel-driven generators for electric lighting.
- g. Secrecy of location is considered of utmost importance. All means are taken to camouflage and conceal tunnel entrances. Often, tunnels are hidden in tombs, walls, floors, or under water.
- h. Extensive use of booby traps and mines should be expected in and around tunnel complexes. Some common booby traps are mortar and artillery duds rigged for command detonation. These may be buried or suspended in trees in the immediate vicinity. Hand

grenades and homemade bombs are used to booby-trapdoors and hatches. Poisonous snakes may be placed in tunnels to inflict casualties.

A-5. Detection of tunnels.

- a. The first step in detecting or locating tunnels is to reduce a large geographical area of interest to a smaller area of probable locations. This can be accomplished by studying general indications of probable tunnel locations.
- b. Some indicators that tunnels are being employed by guerrilla forces are:
 - (1) Movement of guerrillas in a specific direction after being spotted by aircraft.
 - (2) Sniper fire occurring from areas where there are no obvious avenues of withdrawal.
 - (3) Vegetable gardens far from places of habitation.
 - (4) Operations where guerrillas inflict casualties at relatively long range and disappear without making close contact or being detected by friendly forces.
 - (5) The smell of burning wood or food cooking in an area lacking habitation.
- c. Conventional air photography produces results if the appearance of the surface and vegetation are changed from normal. This requires skilled personnel to interpret photos. In a jungle environment, air photography may be prohibited because dense vegetation, such as double or triple canopy jungle, obscures the ground.
- d. Once determined that a specific area may contain a tunnel system, there are several indicators that are helpful in detecting tunnels. Visual inspections often disclose the general area of a tunnel, but not its precise location. The key to finding a tunnel system is the application of common sense to the situation. A platoon or company should be assigned a small search area, never larger than a 1000-meter grid square for a company. These small areas are picked based on intelligence reports or past actions of the guerrilla force. The unit searches every square meter of the area. Some visual indicators usually found are:
 - (1) Worn places on trees that the guerrilla uses as handholds.
 - (2) A small trail, much like a game trail, through the brush into a clump of small trees.
 - (3) Cut trees, although not a sure sign.

- (4) Limbs tied near tree top to conceal the use of a tunnel from aircraft.
 - (5) Slight depression in or around a group of small trees.
 - (6) Air holes, a sure indicator.
 - (7) A lone individual, especially a female, in the area.
 - (8) Fresh cooked food with no one attending the site.
 - (9) Fresh human feces in an area.
- e. All these indicators are good. However, in different areas they may vary. The places to look for indicators are in the corners of hedgerows, in the corners of village huts, and in the secluded corners of trails and streams. The enemy often hides in these places so he can see while not being seen. Additionally, hiding in these places allows those who put the finishing touches on the camouflage to escape undetected. The guerrilla is aware of the danger of establishing a pattern. However, he must have a location that provides him with observation as well as concealment. So look for observation posts that allow him to move into or out of an area undetected.
 - f. Occasionally, the specific location of a tunnel can be obtained by interrogating the local populace, or prisoners of war (PW) who may have occupied, or helped in digging, the system. Because of the method of constructing a tunnel system, that of using an excavation shaft to reach the level of the tunnel and then closing this shaft once the tunnel is completed, the individual may not be able to locate an entrance or exit unless he has seen or used the completed tunnel.

A-6. Tunnel search operations.

- a. Entering an area where a tunnel complex is located requires a methodical approach. Security to the flanks and rear is imperative.
- b. The size of the objective area of operations determines the strength of the unit assigned the search mission. Basically, the unit, company, or platoon is task-organized for tunnel operations.
- c. A company is divided into three elements: security, search, and reserve. (The headquarters element remains with the security element.)
 - (1) Security — one platoon plus headquarters element to cordon search area.
 - (2) Search — one platoon to search immediate area for tunnels. The search element is subdivided into search and security teams.

- (3) Reserve – one platoon to assist in cordon and reinforce as necessary.
- d. A platoon is divided into three elements:
 - (1) Security – one squad plus headquarters element to cordon area.
 - (2) Search – one squad to search area for tunnels. The search element is subdivided into search and security teams.
 - (3) Reserve – one squad to assist in cordon and reinforce as necessary.
- e. The techniques of deliberate search are centered around the rifle squad. Each squad is divided into a security and a search team.
- f. A slow, methodical search is conducted in the area of operations. Once assigned a search area, the squad systematically searches every square meter. The security element move toward the limits of the search area. Once a hole (tunnel) is discovered, the security element surrounds the area while the search team prepares to destroy or neutralize the hole (tunnel).

A-7. Special equipment.

The unit may require the following special items to perform tunnel operations:

- a. Mine detector — used to detect ammunition and weapon caches.
- b. Grenades – fragmentary, chemical (CS) gas, chemical (HC) smoke, white phosphorus (WP), and concussion types. Grenades should not be used after friendly forces have entered a tunnel.
- c. Demolitions — used to destroy tunnel system. Because of the complexity of charges needed to destroy some tunnel complexes, an engineer team should support the search unit. Also, the large amount of demolitions required for some operations may present unique logistical problems, especially in a jungle environment.
- d. Air generator — used to force smoke into tunnel complex.
- e. Flashlights — to search tunnels.
- f. Weapons — caliber .45 pistol should be used inside tunnels. The pistol has good stopping power and is effective at close range.
- g. Loudspeaker — used to call enemy from tunnels.

Section III. Destroying Underground Facilities

A-8. Four-step process.

- a. The destruction of a tunnel is a four-step process, beginning (1) with a soldier firing one or two magazines from a rifle into the tunnel entrance. This has a tendency to discourage the enemy from staying close to the entrance.
- b. After gaining the attention of the guerrillas, they are told to vacate the hole or tunnel or be killed. They may give up without a fight, saving not only the efforts of killing, but of excavating the hole or tunnel for weapons and documents.
- c. If this fails, breaching operations are used(2). A grenade is placed on the entrance cover to gain access. The entrance cover is removed in this manner to minimize the effects of any attached booby traps.
- d. Once the entrance cover is destroyed, the following measures are used (depending on the mission):
 - (1) Insert grenades (3), fragmentary or concussion, to kill the guerrillas. Ensure that the grenades are cooked-off prior to throwing them in the hole or tunnel.
 - (2) Insert a combination of HC smoke and CS chemical grenades. This serves two purposes: HC smoke may reveal the locations of other entrances or exits, and CS may force the guerrillas to evacuate the hole or tunnel. Captured guerrillas become a source of intelligence in finding other holes or tunnels.
- e. The last step (4) is the entry of soldiers to ensure that all weapons and documents are recovered and all enemy dead, wounded, and living are removed. The hole or tunnel is thoroughly searched for small compartments built to hide weapons and ammunition. If a tunnel complex proves to be extensive with bunkers and large rooms, it is cleared systematically. Bunkers are destroyed or occupied to prevent the enemy from reoccupying them through another tunnel. **Do not clear more bunkers than friendly forces can hold.**
- f. Deliberate search techniques emphasize where to look for the enemy (locations that provide him with observation, cover, concealment, and an escape route). When the soldier learns what to look for (a game trail, worn and cut trees, an air hole, human feces, a depression, fresh food, a lone individual), any of these indicators is likely to trigger a mental alert that the enemy is not far away. After the tunnel is searched, it is destroyed with explosives.

A-9. Neutralization-demolition procedures.

- a. **Tunnels.** Since each tunnel system differs in size and construction, a different quantity and placement of explosives is needed for each type.
 - (1) The use of block explosives to destroy a tunnel system has a disadvantage: all the explosive power is concentrated at one point. Thus, the destruction is localized, and often portions of the tunnel are unaffected. However, a large (10-to 12-pound) block of explosive tamped against the ceiling may cause an entire tunnel to collapse.
 - (2) Advantages of block-type explosives are the ease of emplacement, ease of procurement, and feasibility of aerial resupply. Also, block or satchel charges are effective in the destruction of bunkers, sunken living quarters, and underground rooms. Cratering charges are also effective for underground rooms. Short tunnels can be destroyed effectively by block explosives.
 - (3) The shaped charge in tunnel destruction is successful when used in specific circumstances. A shaped charge placed underground in the middle of a tunnel complex, and aimed downward, destroys an area of the tunnel complex around and above the charge. Also, a shaped charge placed in a deep complex and aimed upward results in extensive destruction.
 - (4) Another effective method of tunnel destruction utilizes bangalore torpedos placed throughout the tunnel length (regardless of depth). The constant length of explosives throughout the tunnel ensures complete destruction. The bangalore (5 feet long) is adaptable to the twists and turns in tunnels. Each tunnel where it can be pushed through). A disadvantage of bangalore torpedoes is the logistical problem arising from their size and weight. There may be a problem with resupply if large quantities are used to completely destroy a tunnel system.
- b. **Bunkers.** Underground living quarters, bunkers, and underground hideaways can be destroyed by block or satchel charges placed strategically inside the room. The following are examples of structures and the size and placement of charges.
 - (1) Bunkers dug into the ground and covered by dense brush (average size 4 by 8 by 4 feet) can be destroyed with 3 pounds of explosives placed next to a wall.
 - (2) This bunker (8 by 5 by 4 feet) can be destroyed by placing a 5-pound charge against the roof toward the side of the strongest beam (Figure A-8).

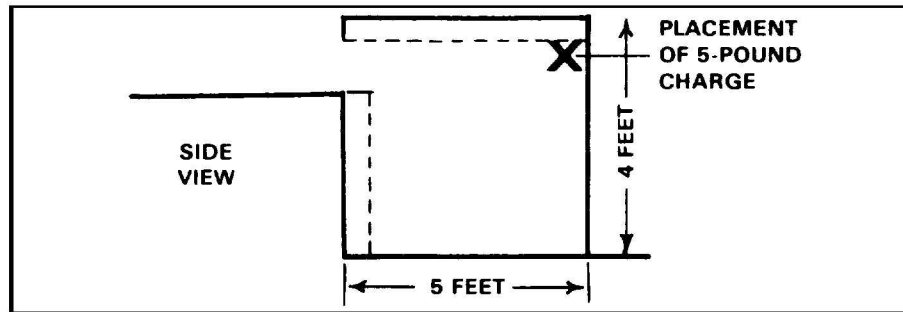

(3) This 4-inch-thick concrete wall bunker (6 by 6 by 5 feet) can be destroyed by placing 8 to 9 pounds of explosives at the point where the tunnel enters the bunker, and will also destroy a portion of the tunnel (Figure A-9).

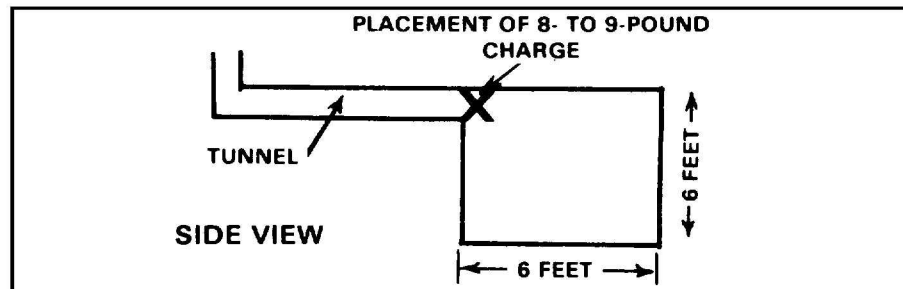

Figure A-9. Reinforced underground bunker.

(4) This bunker depicts an underground hospital capable of holding 10 to 12 persons. It is about 10 feet below the surface. Usually 15 feet long by 8 feet wide by 6 feet high, it is constructed of cement and steel I-beams. The room is completely destroyed by interlacing three bangalore torpedoes in the I-beam rafters (Figure A-10).

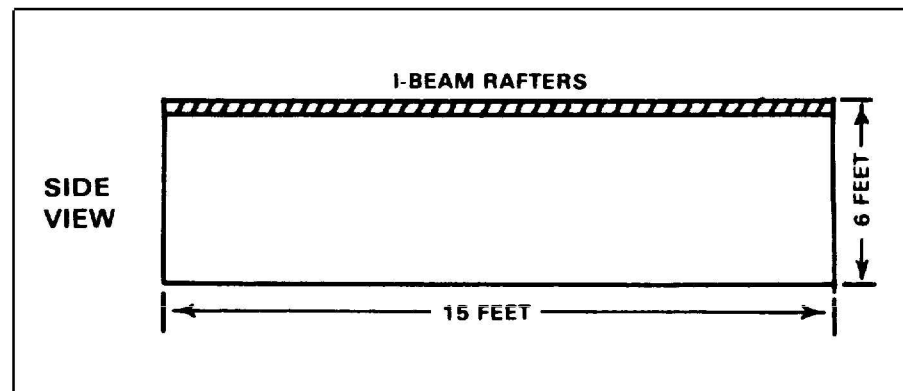
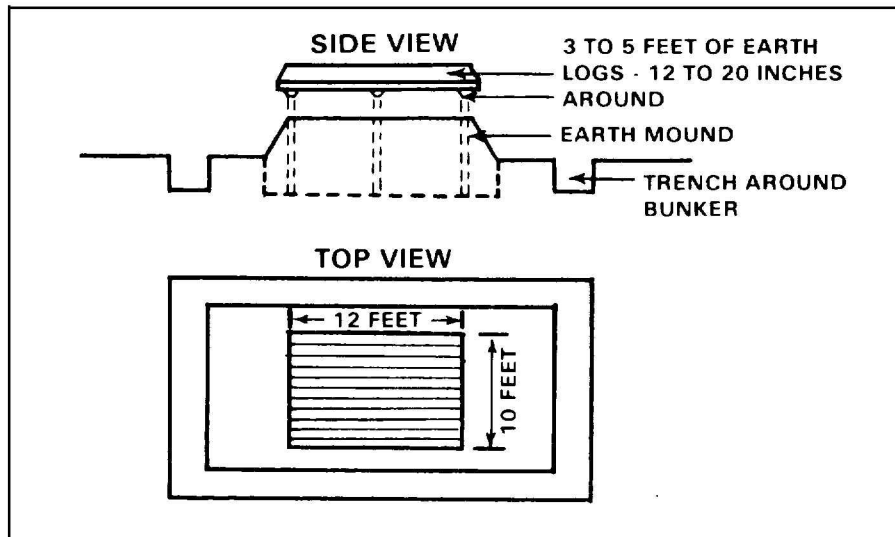

Figure A-10. Underground hospital.

(5) This bunker design requires 10 to 12 pounds of explosives to destroy it (Figure A-11).



APPENDIX B**The Urban Guerrilla****Section I. General****B-1. Effects of the urban environment.**

- a. Cities and towns are vulnerable to urban guerrilla violence because they are the focus of economic and political power. In many cases, public utilities and services can be disrupted. Thus, the government may appear to have lost control of the situation.
- b. The concentration of a large number of people in a relatively small area provides cover for the guerrilla. However, the insurgent may find support only in certain areas of a town or city. In any event, the urban guerrilla lives in a community that is friendly to him or, as a minimum, is too frightened to withhold its support or inform on him. He has a close relationship with leaders and other guerrillas, and may have a communication system using women and children who also provide cover for other activities.
- c. The urban guerrilla can operate more boldly than his rural counterpart as reflected by his tactics: the sniper complements the more conventional ambush and often replaces it; explosive devices may be used either as instruments against the community or more selectively against individuals or groups.
- d. The availability of large numbers of people ensures that crowds can be assembled and demonstrations manipulated with comparative ease. The presence of women and children restricts counter guerrilla force reactions, and a clumsy reaction may ensure a major incident that provides the guerrilla with propaganda. Publicity is easily achieved in an urban area because no major incident can be concealed from the local population even if it is not widely reported by the news media. Terrorist successes may be exploited to discredit the ability of the police, counter guerrilla force, and civil government to provide protection and control the guerrillas.
- e. The urban guerrilla cannot, like his rural counterpart, establish bases and recruit large military units. He is an individual, a member of a relatively small group, relying on the cover afforded by the people of the city and on terror to avoid betrayal. Individuals and small groups are effective in an urban environment because it is easier for them to avoid capture; if captured, however, the terrorist may be able to expose only two or three persons to government or counter guerrilla forces.

B-2. Guerrilla tactics.

- a. The urban guerrilla works alone or in small cells, and his tactics are different from those of his rural counterpart.
- b. They include:
 - (1) Disrupting industry and public services by strikes and sabotage.
 - (2) Generating widespread disturbances designed to stretch the resources of the counter guerrilla force.
 - (3) Creating incidents or massing crowds in order to lure the counter guerrilla force into a trap.
 - (4) Provoking the counter guerrilla force in the hope that it may overreact and provide hostile propaganda.
 - (5) Fomenting interfactional strife.
 - (6) Sniping at roadblocks, outposts, and sentries.
 - (7) Attacking vehicles and buildings with rockets and mortars.
 - (8) Planting explosive devices, either against specific targets or indiscriminately, to cause confusion and destruction, and to lower public morale.
 - (9) Ambushing patrols and firing on helicopters.

Section II. Techniques to Counter the Urban Guerrilla

B-3. Urban counter guerrilla operations.

- a. Operations against urban guerrillas may vary from a passive policy designed to curtail terrorist activities so that community life can continue (under certain constraints), to an active policy which involves the counter guerrilla force seeking out and capturing or killing the enemy. The level of intensity at which operations are conducted will be determined by the civil government.
- b. Fighting the urban guerrilla is generally a police mission. However, the military counter guerrilla force commander maybe required to assist the police in this mission or even take it over. The techniques used are similar to the ones used in rural areas. Before operations are conducted, information must be obtained about the enemy, his environment, and operations (Appendix H). The techniques include:
 - (1) Installation of base defense (Appendix E).
 - (2) Roadblocks and checkpoints (Chapter 3).

- (3) Crowd dispersal (FM 19-15).
- (4) Cordon-and-search operations (Chapter 3).
- (5) Patrols (Chapter 3 and Appendix D).

B-4. Minimum force.

The principles remain the same, but in an urban environment the principle of minimum force becomes more important and is directly related to the rules of engagement. There is greater danger of injuring or killing innocent civilians in heavily populated centers. Since there are seldom large groups of guerrillas in cities, there are no base camps, only safe houses. Opportunities for deliberate attacks rarely occur. Just as fighting guerrillas in a rural environment, killing or capturing the urban guerrilla is not a mission that is quickly accomplished.

APPENDIX C

Ambush Patrols**Section 1. General****C-1. Purpose of ambushes.**

The ambush patrols discussed in this appendix are combat patrols with missions to establish and execute ambushes to harass or destroy targets and/or capture personnel and equipment. Ambushes generally are executed to reduce the guerrilla's overall combat effectiveness. Destruction is the primary purpose of an ambush since guerrillas killed and/or captured, and equipment and/or supplies destroyed or captured, critically affect the guerrilla force. Harassment, the secondary purpose, diverts guerrillas from other missions. A series of successful ambushes causes the guerrilla force to be less aggressive and more defensive; to be apprehensive and overly cautious; and to be reluctant to go on patrols and move in convoys or in small groups.

C-2. Types of ambushes.

- a. There are two types of ambushes. A point ambush involves patrol elements deployed to support the attack of a single killing zone. An area ambush involves patrol elements deployed as multiple, related, point ambushes.
- b. An ambush is categorized as either hasty or deliberate. A hasty ambush is an immediate action drill, an action of a combat patrol with little or no information. When information does not permit detailed planning required for a deliberate ambush, a hasty ambush is planned. In this case, the ambush patrol plans and prepares to attack the first suitable guerrilla force. A deliberate ambush is planned as a specific action against a specific target. Detailed information of the guerrilla force is required: size, nature, organization, armament, equipment, route and direction of movement, and times the force will reach or pass certain points on its route. Deliberate ambushes are planned when:
 - (1) Reliable information is received on the intended movement of a specific force.
 - (2) Patrols, convoys, carrying parties, or similar forces establish patterns of size, time, and movement sufficient to permit detailed planning for the ambush.
- c. A unit conducting a combat patrol, before departing, plans and rehearses the ambush of the type of guerrilla force it may

encounter. It establishes and executes ambushes as opportunities arise.

Section II. Attack Fundamentals

C-3. Three elements.

Surprise, coordinated fires, and control are basic to a successful ambush.

C-4. Surprise.

Surprise must be achieved or else the attack is not an ambush. Surprise, which distinguishes an ambush from other forms of attack, allows the ambush force to seize and retain control of the situation. Surprise is achieved by careful planning, preparation, and execution. Guerrillas are attacked in a manner they least expect.

C-5. Coordinated fires.

All weapons, including mines and demolitions, are positioned, and all direct and indirect fires are coordinated to achieve:

- a. Isolation of the kill zone to prevent escape or reinforcement.
- b. Surprise delivery of a large volume of concentrated fires into the kill zone to inflict maximum damage so the target can be assaulted and destroyed.

C-6. Control.

- a. Close control is maintained during movement to, occupation of, and withdrawal from the ambush site.
- b. The ambush commander's control of all elements is critical at the time of target approach. Control measures provide for
 - (1) Early warning of target approach.
 - (2) Withholding fire until the target moves into the kill zone.
 - (3) Opening fire at the proper time.
 - (4) Initiating appropriate actions if the ambush is prematurely detected.
 - (5) Lifting or shifting supporting fires when the ambush includes assault of the target.
 - (6) Timely and orderly withdrawal to an easily recognized rallying point.

- c. Personnel conducting the ambush remain still and quiet while waiting for the target to appear. They may have to forgo smoking; endure insect bites and thirst in silence; and resist sleeping, easing cramped muscles, and performing normal body functions. (Ambushes should have a rest plan and a mess plan.) When the target approaches, they do not open fire before the signal is given.

Section III. Planning

C-7. Flexibility.

- a. An ambush is planned and prepared using troop leading procedures. Planning considerations include whether the ambush is to be a deliberate ambush or a hasty ambush. In a deliberate ambush, more target intelligence is available to permit planning for every course of action at the target. Planning for a hasty ambush includes tentative plans both for the types of targets that may be ambushed and for varying situations. Both plans are flexible enough to allow modifying, as appropriate, at the ambush site. All plans are rehearsed in detail.
- b. Planning provides for the following:
 - (1) **Simplicity.** Every soldier must thoroughly understand what he is to do at every stage of the operation. In an ambush, more so than in other operations, the failure of even one soldier to perform exactly as planned can cause failure.
 - (2) **Type of ambush.** The type of ambush affects the organization, number of men, and amount of equipment and communications required.
 - (3) **Deployment.** Each possible formation is considered for its advantages and disadvantages.

C-8. Manner of attack.

The attack may be by fire only (harassing ambush) or may include assault of the target (destruction ambush).

C-9. Size of ambush force.

The force is tailored for its mission. Two men may be adequate for a harassing ambush. A destruction ambush may require the entire unit (squad, platoon, company).

- a. **Organization.** An ambush patrol is organized in the same manner as other combat patrols to include a headquarters, an assault element, a support element, and a security element. The assault and support elements are the attack force; the security

element is the security force. When appropriate, the attack force is further organized to provide a reserve force. When an ambush site is to be occupied for an extended period, double ambush forces may be organized. One ambush force occupies the site while the other rests, eats, and tends to personal needs at the objective rail yard or other concealed location. They alternate after a given time, which is usually 8 hours. If the waiting period is over 24 hours, three ambush forces may be organized.

- b. **Equipment.** The selection of equipment and supplies is based on the:
 - (1) Mission.
 - (2) Size of the guerrilla force.
 - (3) Means of transportation.
 - (4) Distance and terrain.
 - (5) Weight and bulk of equipment.
- c. **Routes.** A primary route is planned which allows the unit to enter the ambush site from the rear. The kill zone is not entered if entry can be avoided. If the kill zone must be entered to place mines or explosives, care is taken to remove any tracks or signs that might alert the guerrillas and compromise the ambush. If mines, mantraps, or explosives are to be placed on the far side, or if the appearance of the site might cause the guerrillas to check it, then a wide detour around the kill zone is made. Here, too, care is taken to remove any traces which might reveal the ambush. Also, an alternate route from the ambush site is planned.
- d. **Site.** Maps and aerial photographs are used to analyze the terrain. When possible, non-the-ground reconnaissance is made. As far as possible, so-called "ideal" ambush sites are avoided. Alert guerrillas are suspicious of these areas, avoid them if possible, and increase vigilance and security when they must be entered; surprise is even more difficult to achieve in these areas. Instead, apparently unlikely sites are chosen, when possible. Considering this, an ambush site must provide:
 - (1) Fields of fire.
 - (2) Concealed positions.
 - (3) Canalization of the guerrillas into the killing zone.
 - (4) Covered routes of withdrawal (to enable the ambush force to break contact and avoid pursuit).
 - (5) No exit route for the guerrilla force.
- e. **Occupation of the site.** As a rule, the ambush force occupies the ambush site at the latest possible time permitted by the tactical

situation and the amount of site preparation required. This not only reduces the risk of discovery but also reduces the time that soldiers must remain still and quiet in position.

- f. **Positions.** The unit moves into the ambush site from the rear. Security elements are positioned first to prevent surprise while the ambush is being established. Automatic weapons are then positioned so that each can fire along the entire killing zone. If this is not possible, they are given overlapping sectors of fire so that the entire killing zone is covered. The unit leader then selects his position, located where he can see when to initiate the ambush. Claymore mines, explosives, and M203 grenade launchers maybe used to cover any dead space left by the automatic weapons. All weapons are assigned sectors of fire to provide mutual support. The unit leader sets a time by which positions are to be prepared. The degree of preparation depends on the time allowed. All men work at top speed during the allotted time.
- g. **Camouflage.** Camouflage is important. Each soldier must be hidden from the target. During preparation for the patrol, each soldier camouflages himself and his equipment and secures his equipment to prevent noise. At the ambush site, positions are prepared with minimal change in the natural appearance of the site. All debris resulting from preparation of positions is concealed.
- h. **Movement, noise, and light discipline.** Movement is kept to a minimum and the number of men moving at a time is closely controlled. Every man is as quiet as possible, especially at night. Light discipline is rigidly enforced at night. Smoking is forbidden at night and is closely controlled in the day.

C-10. Execution.

- a. Three signals, often four, are needed to execute the ambush. Audible and visual signals, such as whistles and pyrotechnics, must be changed often to avoid establishing patterns. Too frequently, use of the same signals may result in their becoming known to the enemy. A guerrilla might recognize a signal and be able to react in time to avoid the full effects of an ambush. For example, if white star cluster is habitually used to signal withdrawal in a night ambush, an alert guerrilla might fire one and cause premature withdrawal.
- b. A signal by the security force to alert the patrol leader to the guerrilla's approach may be given by:
 - (1) Arm-and-hand signals.
 - (2) Radio, as a quiet voice message, by transmitting a prearranged number of taps, or by signaling with the push-to-talk switch.

- (3) Field telephone, when there is no danger that wire between positions will compromise the ambush.
- c. A signal to initiate the ambush, given by the patrol leader or a designated individual, may be a shot or the detonation of mines or explosives. The ambush should be initiated with a mass casualty producing weapon (Claymore antipersonnel mine or M60 machine gun).
- d. A signal for lifting or shifting fires, if the guerrilla force is to be assaulted, may be given by voice command, whistles, or pyrotechnics. All fire stops immediately so that the assault can be made before the guerrilla can react.
- e. A signal for withdrawal may also be by voice command, whistles, or pyrotechnics.

C-11. Fire discipline.

This is a key part of the ambush. Fire is withheld until the signal is given, then immediately delivered with the heaviest, most accurate volume possible. Properly timed and delivered fires contribute to the achievement of surprise as well as to destruction of the guerrilla force. When the guerrillas are to be assaulted, the lifting or shifting of fires is equally precise. Otherwise, the assault is delayed, and the guerrillas have an opportunity to recover and react.

C-12. Withdrawal to the objective rallying point.

- a. The objective rallying point is far enough from the ambush site so that it will not be overrun if the guerrilla force attacks the ambush. Routes of withdrawal to the objective rallying point are reconnoitered. If possible, each person walks the route he is to use and picks out checkpoints. When the ambush is to be executed at night, each person must be able to follow his route in the dark.
- b. On signal, the unit quickly but quietly withdraws to the objective rallying point, reorganizes, and begins its return march.
- c. If the ambush was not successful and the unit is pursued, withdrawal may be by bounds. The last group may arm mines, previously placed along the withdrawal route, to further delay pursuit.

C-13. Four ambush techniques.

- a. A *near ambush* is a point ambush with the assault element within reasonable assaulting distance of the kill zone (less than 50 meters). Close terrain, such as jungle and heavy woods, may

- require this positioning. It may also be appropriate in open terrain in a “rise from the ground” ambush.
- b. A *far ambush* is a point ambush with the assault element beyond reasonable assaulting distance of the kill zone (beyond 50 meters). This location may be appropriate in open terrain offering good fields of fire or when attack is by fire for a harassing ambush.
 - c. A *harassing ambush* is an ambush in which attack is by fire only.
 - d. A *destruction ambush* is an ambush which includes assault to close with and decisively engage the guerrilla force.

Section IV. Point Ambush Formations

C-14. Positions.

- a. A point ambush, whether independent or part of an area ambush, is positioned along the expected route of approach of the guerrilla force. Formation is important because, to a great extent, it determines whether a point ambush can deliver the heavy volume of highly concentrated fire necessary to isolate, trap, and destroy the guerrillas.
- b. The formation to be used is determined by carefully considering possible formations and the advantages and disadvantages of each in relation to terrain; conditions of visibility, forces, weapons, and equipment ease or difficulty of control; force to be attacked; and overall combat situation.
- c. This section discusses formations developed for the deployment of point ambushes. The formations are identified with names that correspond to the general pattern formed on the ground by deployment of the attack element. They include:
 - (1) Line formation (two techniques, Paragraph C-15).
 - (2) L-formation (two techniques with variations, Paragraph C-16).
 - (3) Z-formation (Paragraph C-17).
 - (4) T-formation (two techniques, Paragraph C-18).
 - (5) V-formation (two techniques, Paragraph C-19).
 - (6) Triangle formation (closed; open with variations, Paragraph C-20).
 - (7) Box formation (two techniques, Paragraph C-21).

C-15. Line formation.

- a. The attack element is deployed generally parallel to the guerrilla force's route of movement (road, trail, stream). This positions the

attack element parallel to the long axis of the kill zone and subjects the guerrilla force to heavy flanking fire. The size of the force that can be trapped in the kill zone is limited by the area which the attack element can effectively cover with highly concentrated fire. The force is trapped in the kill zone by natural obstacles, mines (Claymore, antivehicular, antipersonnel), demolition's, and direct and indirect fires (Figure C-1).

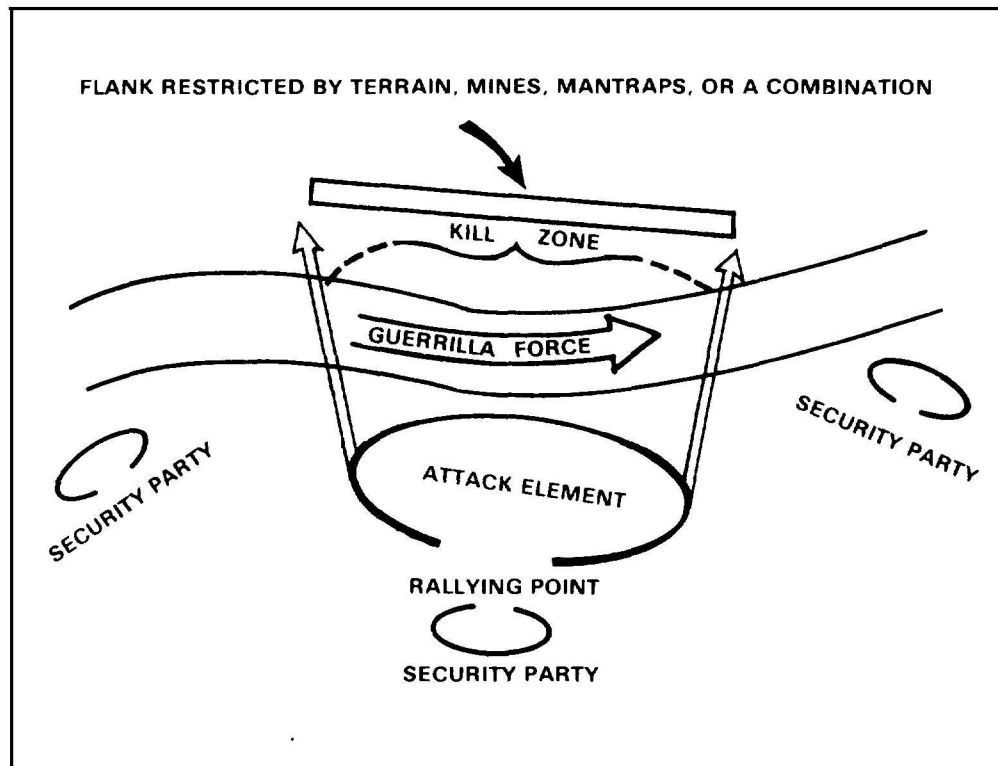

Figure C-1. Line formation: harassing or destruction ambush.

- b. A disadvantage of the line formation is the chance that lateral dispersion of the force maybe too great for effective coverage. The line formation is appropriate in close terrain that restricts guerrilla maneuver and in open terrain where one flank is restricted by mines, demolitions, or mantraps. Similar obstacles can be placed between the attack element and the kill zone to provide protection from guerrilla counterambush measures. When a destruction ambush is deployed in this manner, access lanes are left so that the force in the killing zone can be assaulted. The line formation can be effectively used by a “rise from the ground” ambush in terrain seemingly unsuitable for ambush (Figure C-2).

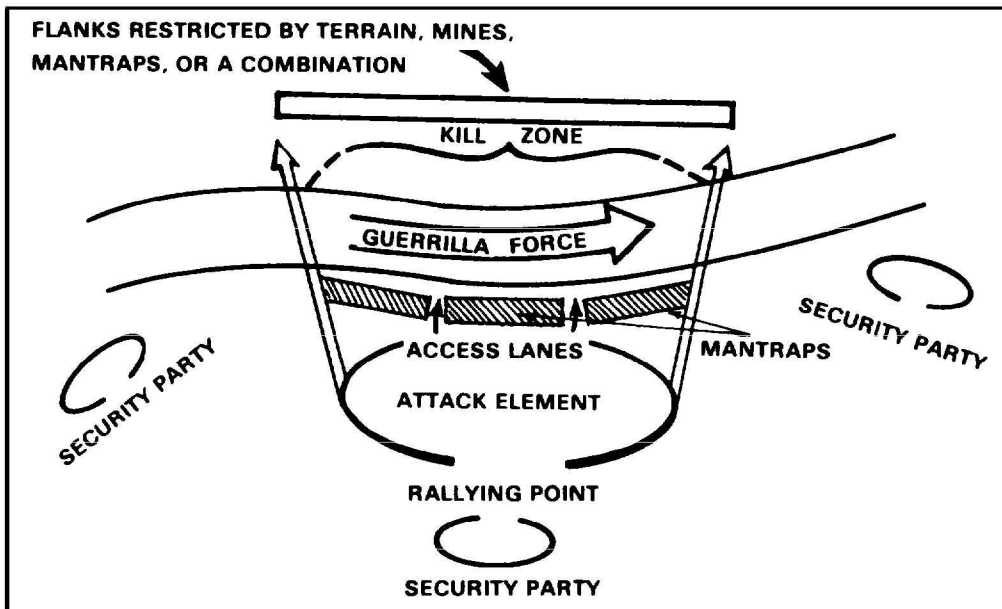

Figure C-2. Line formation: destruction ambush with access lanes for assault of target.

- c. An advantage of the line formation is its relative ease of control under all conditions of visibility.

C-16. L-formation.

- a. The L-shaped formation is a variation of the line formation. The long side of the attack element is parallel to the kill zone and delivers flanking fire. The short side of the attack element is at the end of, and at right angles to, the kill zone and delivers enfilading fire that interlocks with fire from the other leg (Figure C-3).

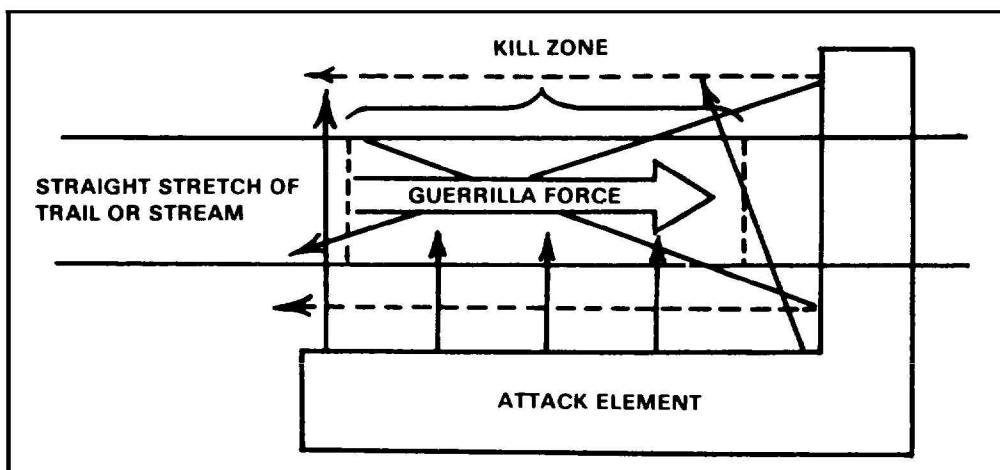

Figure C-3. L-formation: destruction ambush.

- b. This formation is flexible. It can be established on a straight stretch of a trail or stream or at a sharp bend in a trail or stream (Figure C-4).

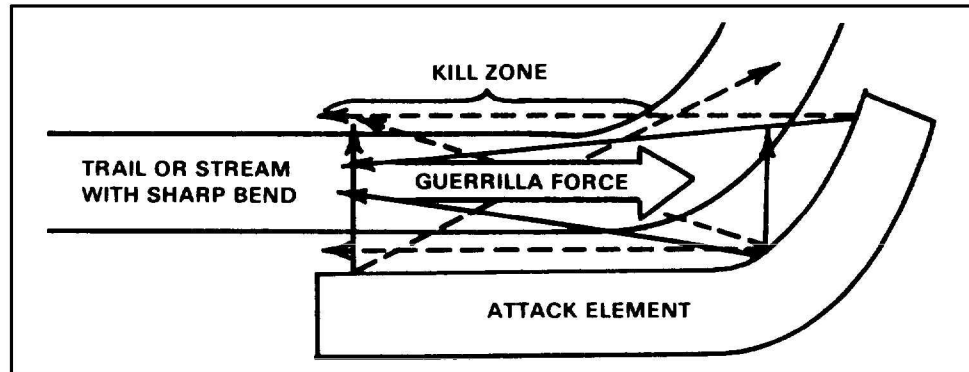

Figure C-4. L-formation: destruction ambush at bend of trail or stream.

- c. When appropriate, fire from the short leg can be shifted to parallel the long leg if the guerrilla force attempts to assault or escape in the opposite direction. In addition, the short leg prevents escape in that direction or reinforcement from that direction (Figure C-5).

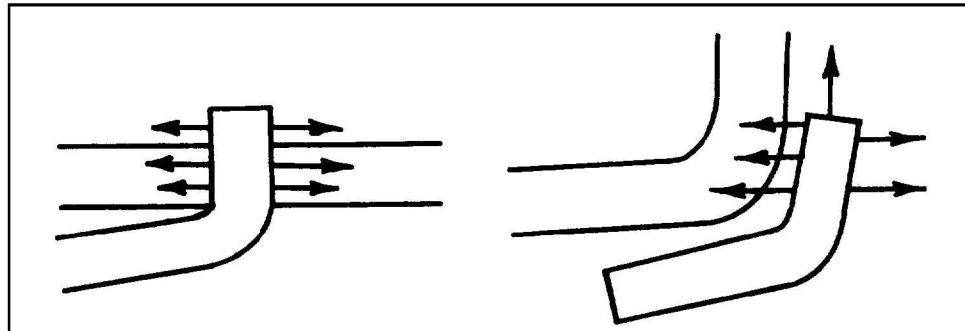

Figure C-5, L-formation: short leg prevents escape or reinforcement.

C-17. Z-formation.

The Z-shaped formation is another variation of the L-formation. The attack force is deployed as in the L-formation but with an additional side so that the formation resembles the letter Z. The additional side may serve to (Figure C-6):

- Engage a force attempting to relieve or reinforce the guerrillas.
- Restrict a flank.
- Prevent envelopment (of the ambush force).
- Seal the end of the kill zone.

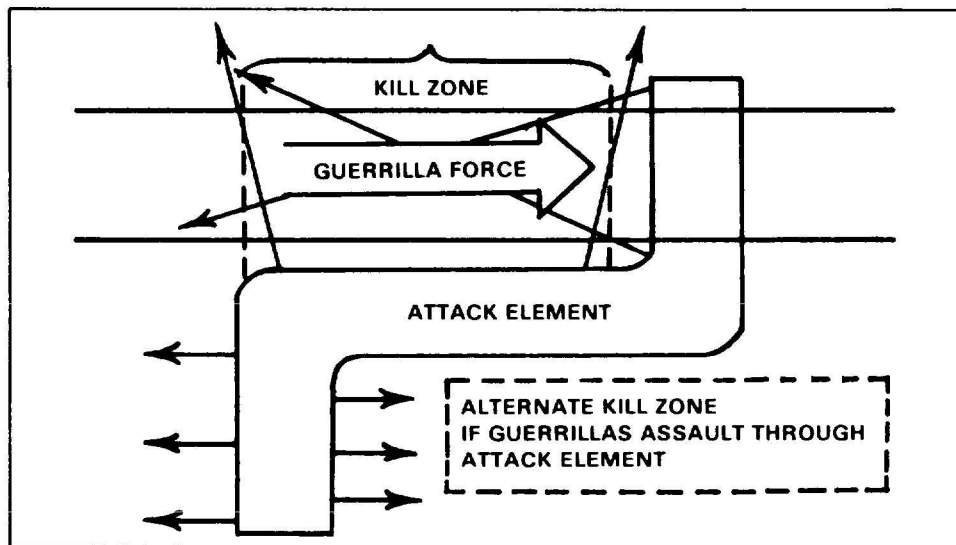

Figure C-6. Z-formation: destruction ambush.

C-18. T-formation.

- a. In the T-shaped formation, the attack element is deployed across, and at right angles to, the route of movement of the hostile force so that the attack element and the target form the letter T. This formation can be used day or night to establish a purely harassing ambush, and at night to establish an ambush to interdict movement through open, hard-to-seal areas (such as rice paddies).
- b. A small unit can use the T-formation to harass, slow, and disorganize a larger force. When the lead guerrilla elements are engaged, they will normally attempt to maneuver right or left to close with the ambush force. Mines, mantraps, and other obstacles placed to the flanks of the kill zone slow the guerrilla's movement and permit the unit to deliver heavy fire and then withdraw without becoming decisively engaged. (Figure C-7).
- c. The T-formation can be used to interdict small groups attempting night movement across open areas. For example, the attack element may be deployed along a rice paddy dike with every second member facing in the opposite direction. The attack of a force approaching from either direction requires only that every second member shift to the opposite side of the dike. Each member fires only to his front and only when the target is at close range. Attack is by fire only, and each member keeps the guerrilla force under fire as long as it remains to his front. If the force attempts to escape in either direction along the dike, each member takes it under fire as it comes into his vicinity. The T-formation is effective at halting infiltration. (Figure C-8).

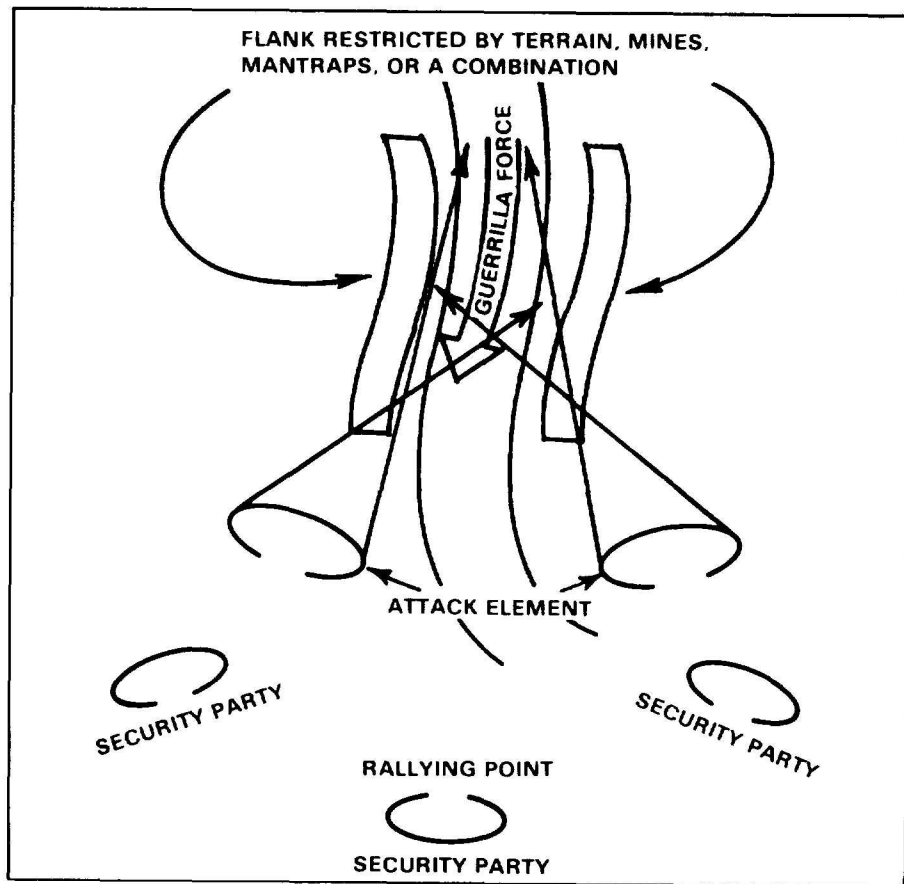

Figure C-7. T-formation: harassing ambush.

d. It has one chief disadvantage: there is a possibility that while spread out the ambush will engage a superior force. Use of this formation must, therefore, fit the local enemy situation.

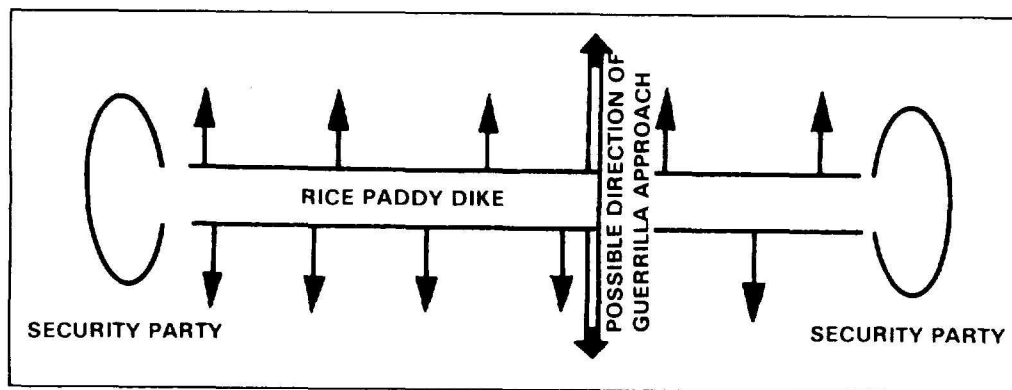

Figure C-8. T-formation: rice paddy harassing ambush where guerrilla approach may be from either direction.

C-19. V-formation.

- a. The V-shaped attack element is deployed along both sides of the guerrilla route of movement so that it forms a V. Care is taken to ensure that neither group (or leg) fires into the other. This formation subjects the guerrilla to both enfilading and interlocking fire (Figure C-9).

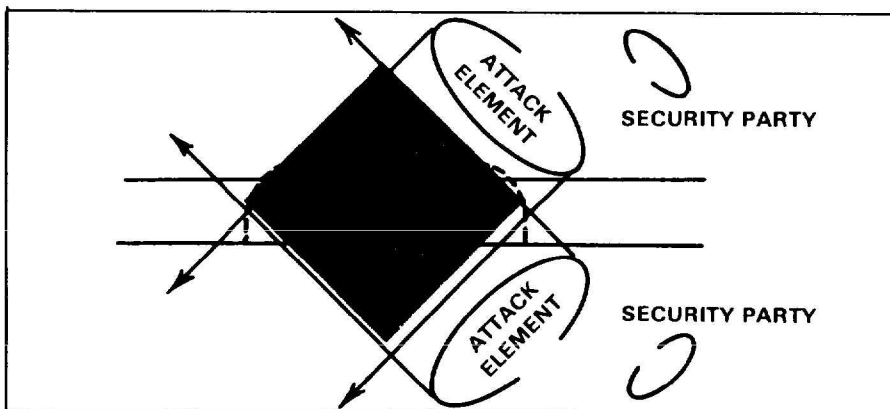

Figure C-9. V-formation.

- b. The V-formation is suited for fairly open terrain but can also be used in the jungle. When established in the jungle, the legs of the V close in as the lead elements of the guerrilla force approach the apex of the V; elements then open fire from close range. Here, even more than in open terrain, all movement and fire is carefully coordinated and controlled to ensure that the fire of one leg does not endanger the other. Wider separation of the elements makes this formation difficult to control, and there are fewer sites that favor its use. Its main advantage is that it is difficult for the guerrilla to detect the ambush until well into the kill zone (Figure C-10).

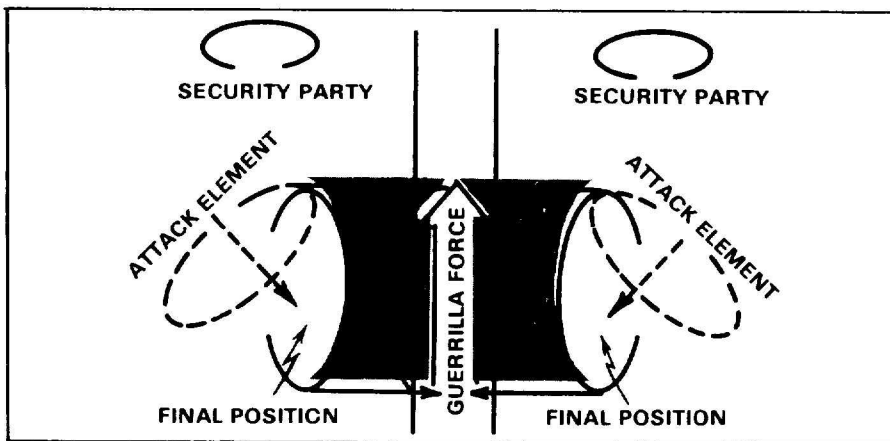

Figure C-10. V-formation (close range).

C-20. Triangle formation.

This is a variation of the V-formation and can be employed in three ways:

- a. **Closed triangle.** The attack element is deployed in three groups, positioned so that they form a triangle (or closed V). An automatic weapon is placed at each point of the triangle and positioned so that it can be shifted quickly to interlock with either of the others. Elements are positioned so that their fields of fire overlap. Mortars may be positioned inside the triangle. When deployed in this manner, the triangle ambush becomes a small unit strongpoint which is used to interdict night movement through open areas, when guerrilla approach is likely to be from any direction. The formation provides all-round security, and security elements are deployed only when they can be positioned so that, if detected by an approaching target, they will not compromise the ambush. Attack is by fire only, and the target is allowed to approach within close range before the ambush force opens fire (Figure C-11).

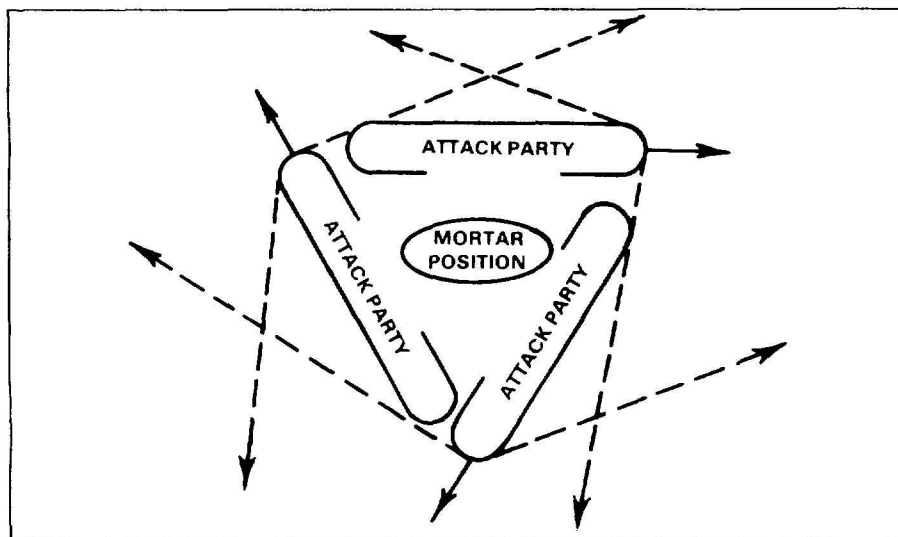

Figure C-11. Closed triangle.

- (1) Advantages include ease of control, all-round security, and guerrillas approaching from any direction can be fired on by at least two automatic weapons.
- (2) Disadvantages include the requirement for an ambush force of platoon size or larger to reduce the danger of being overrun by a large guerrilla force; one or more legs of the triangle may come under guerrilla enfilade fire; and lack of dispersion, particularly at the points, increases danger from guerrilla mortar fire.

b. **Open triangle (harassing ambush).** This variation of the triangle ambush is designed to enable a small unit to harass, slow, and inflict heavy casualties upon a larger force without being decisively engaged. The attack group is deployed in three elements, positioned so that each element becomes a corner of a triangle containing the kill zone. When the guerrillas enter the kill zone, the element to the guerrillas' front opens fire on the lead guerrillas. When the guerrillas counterattack, the element withdraws and an assault element to the flank opens fire. When this group is attacked, the element to the opposite flank opens fire. This process is repeated until the guerrillas are pulled apart. Each element reoccupies its position, if possible, and continues to inflict maximum damage without becoming decisively engaged (Figure C-12).

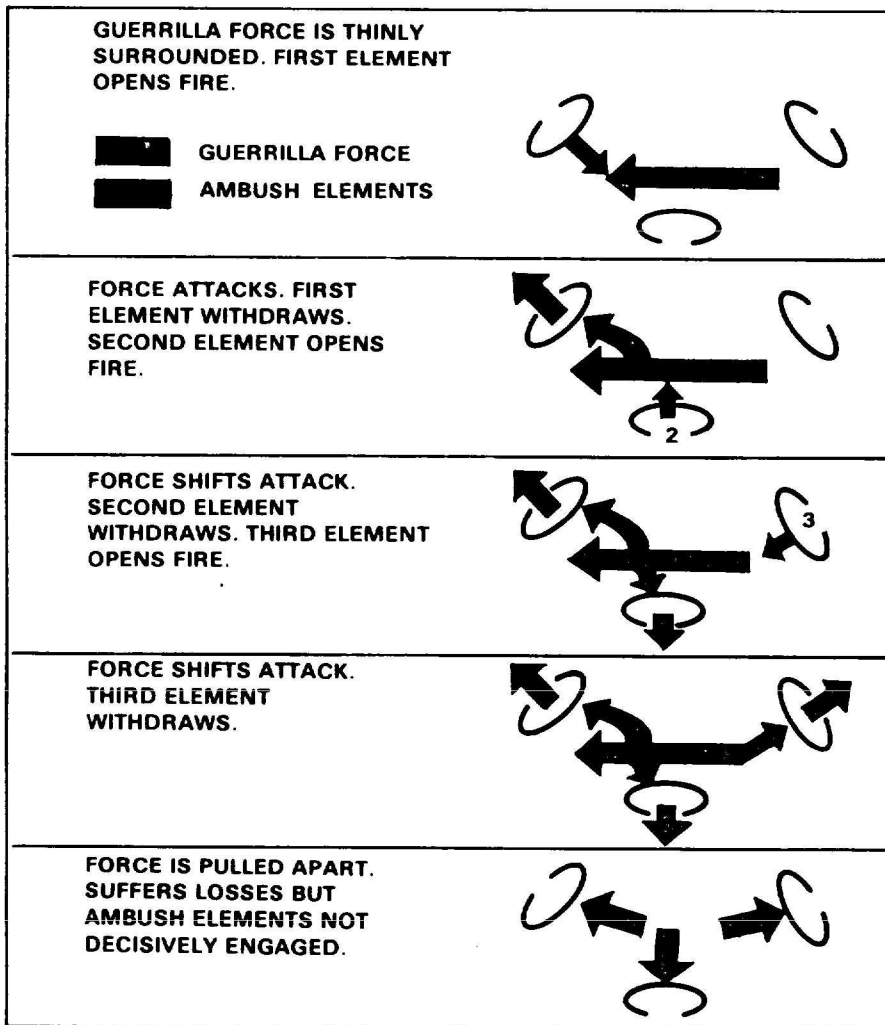

Figure C-12. Open triangle formation: harassing ambush.

- c. **Open triangle (destruction ambush).** The attack group is again deployed in three elements, positioned so that each element is a point of the triangle, 200 to 300 meters apart. The kill zone is the area within the triangle. The guerrillas are allowed to enter the killing zone; the nearest element attacks by fire. As the guerrillas attempt to maneuver or withdraw, the other elements open fire. One or more assault elements, as directed, assault or maneuver to envelop or destroy the guerrillas (Figure C-13).

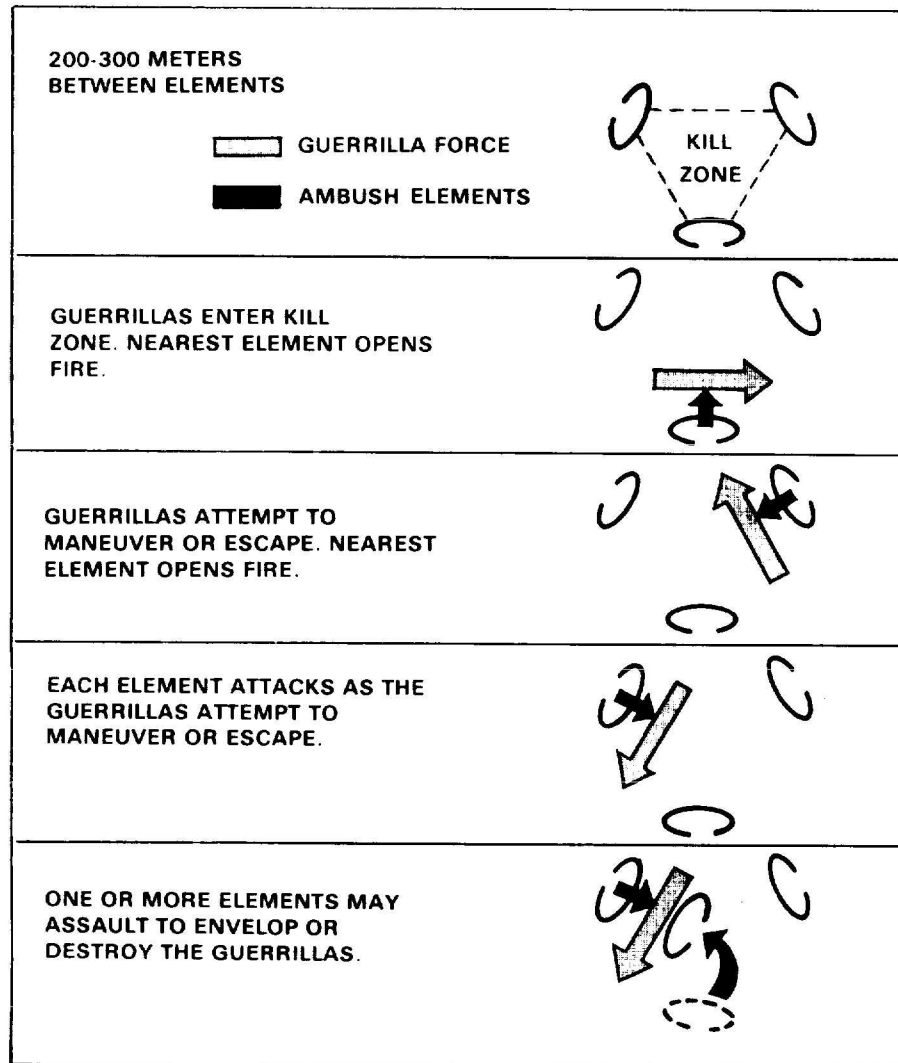

Figure C-13. Open triangle formation: destruction ambush.

- (1) As a destruction ambush, this formation is suitable for platoon-size or larger units; a unit smaller than a platoon would be in danger of being overrun.

- (2) Also, control, in assaulting or maneuvering, is difficult. Close coordination and control are necessary to ensure that assaulting or maneuvering assault elements are not fired on by another party; and the ambush site must be a fairly level, open area that provides (around its border) concealment for the ambush elements (unless it is a “rise from the ground” ambush).

C-21. Box formation.

- a. This formation is similar in purpose to the open triangle ambush. The unit is deployed in four elements positioned so that each element becomes a corner of a square or rectangle containing the kill zone (Figure C-14).

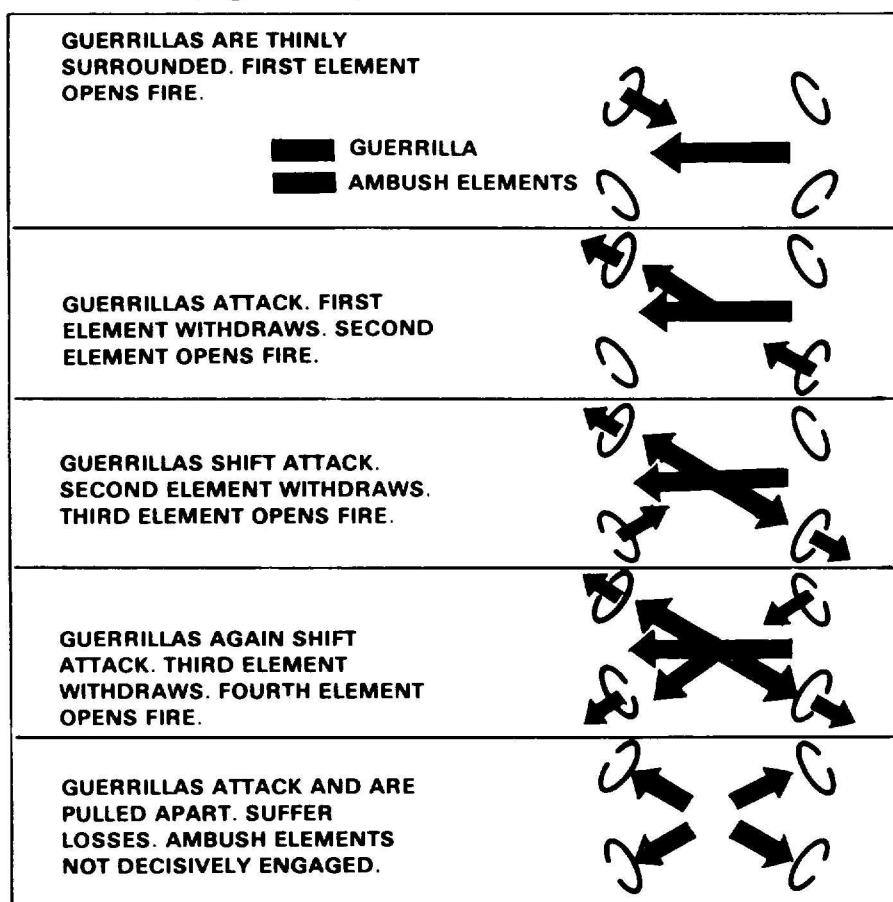

Figure C-14. Box formation: harassing ambush.

- b. It can be used as a harassing ambush or a destruction ambush in the same manner as the two variations of the open triangle ambush (Figure C-15).

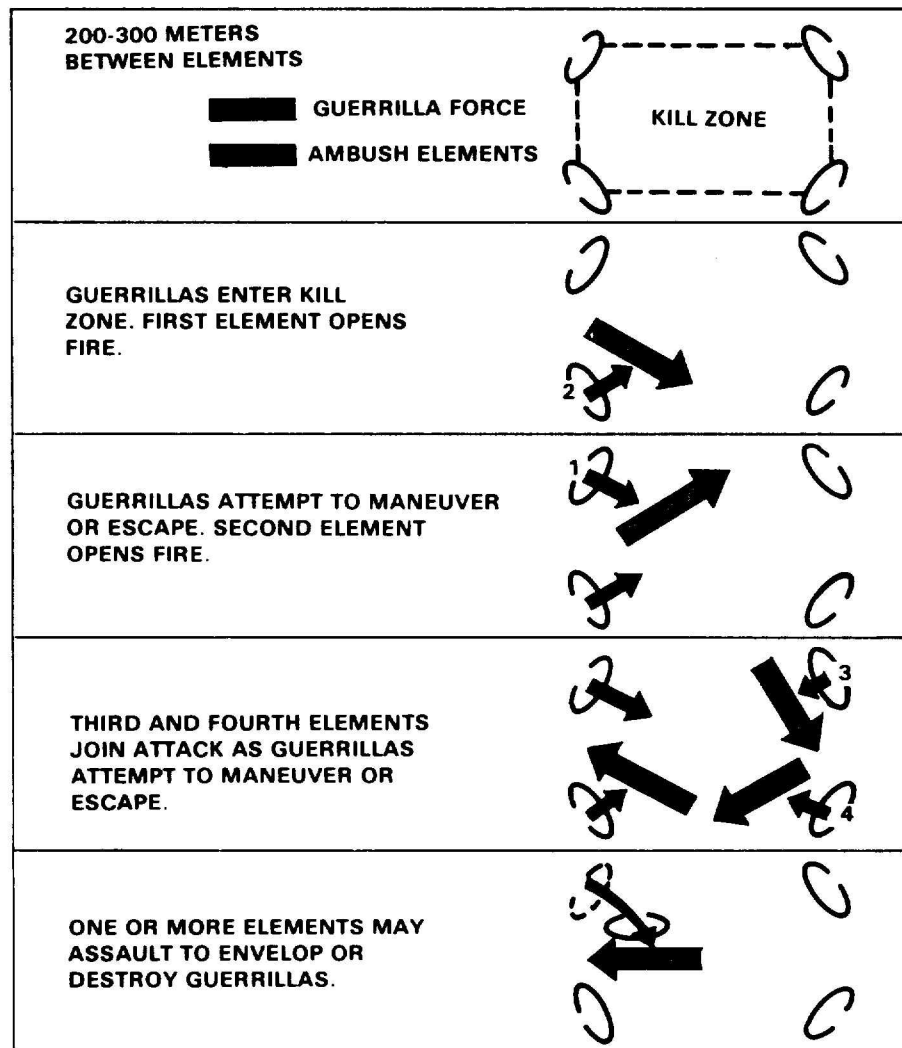

Figure C-15. Box formation: destruction ambush.

Section V. Area Ambush Formations

C-22. Kill zone.

A point ambush is established at a site having several trails or other escape routes leading away from it. The site may be a water hole, guerrilla campsite, or known rendezvous point, or a frequently traveled trail. This site is the central kill zone.

C-23. Area ambush: multiple point

- a. Point ambushes are established along the trails or other escape routes leading away from the central kill zone (Figure C-16).

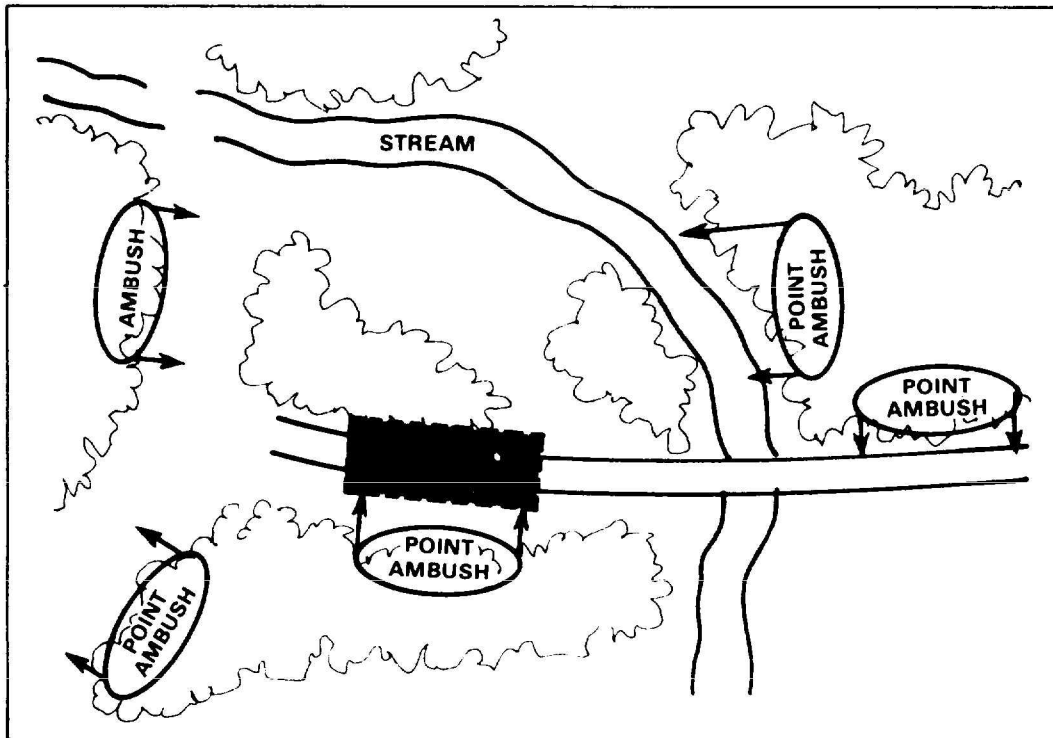

Figure C-16. Area (multiple point) ambush.

- b. The guerrilla force, whether a single group or several parties approaching from different directions, is permitted to move to the central kill zone. Outlying ambushes do not attack (unless discovered).
- c. The ambush is initiated when the guerrillas move into the central kill zone.
- d. When the guerrillas break contact and attempt to disperse, escaping portions are intercepted and destroyed by the outlying ambushes.
- e. The multiple point ambush increases casualties and harassment and produces confusion.
- f. This version of the area ambush is best suited in terrain where movement is largely restricted to trails. It provides best results when established as a deliberate ambush. When there is not sufficient intelligence for a deliberate ambush, an area ambush of opportunity (hasty ambush) may be established. The outlying ambushes are permitted to attack guerrillas approaching the central kill zone, if the guerrilla force is small. If it is too large for the particular outlying ambush, the guerrillas are allowed to continue and they are attacked in the central kill zone.

C-24. Area ambush: baited trap

- a. A variation of the area ambush is the "baited trap" ambush.
- b. A central kill zone is established along the guerrilla's route of approach.
- c. Point ambushes are established along the routes over which units relieving or reinforcing the guerrilla will have to approach.
- d. The guerrilla force in the central kill zone serves as "bait" to lure relieving or reinforcing guerrilla units into the kill zones of the outlying ambushes. A friendly force can also be used as the "bait."
- e. The outlying point ambushes need not be strong enough to destroy their targets. They may be small harassing ambushes that delay, disorganize, and cause casualties by successive contacts.
- f. This version can be varied by using a fixed installation as "bait" to lure relieving or reinforcing guerrilla units into the kill zone of one or more of the outlying ambushes. The installation replaces the central kill zone and is attacked. The attack may intend to overcome the installation or may use it as a ruse.
- g. These variations are best suited for situations where routes of approach for relieving or reinforcing guerrilla units are limited to those favorable for ambush (Figure C-17).

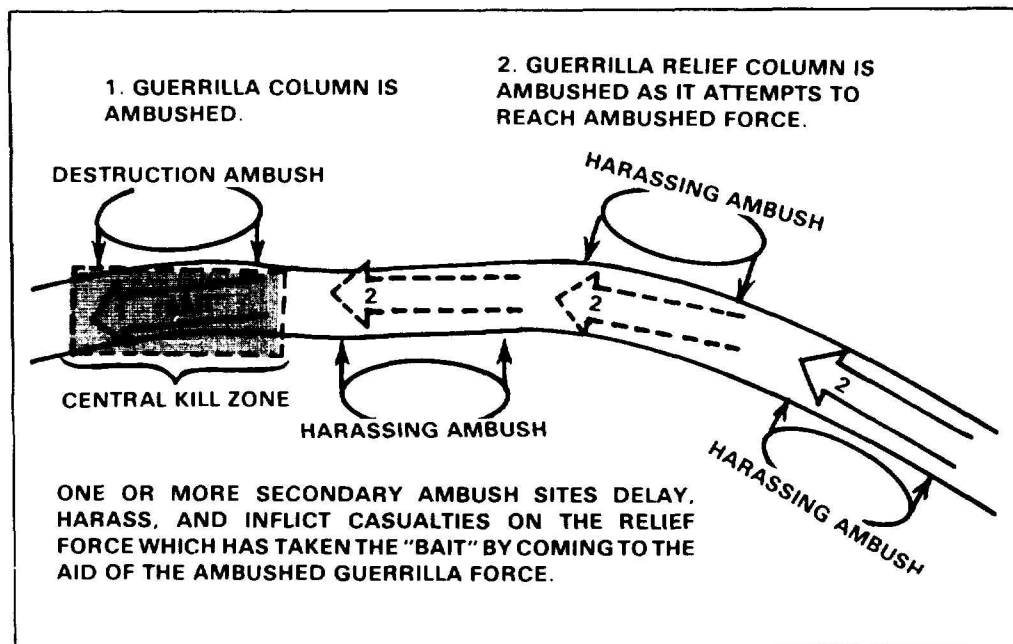

Figure C-17. Area (baited trap) ambush

Section VI. Unusual Ambush Techniques

C-25. Spider hole ambush.

- a. This point ambush is designed for open areas that lack the cover and concealment and other features normally desirable in a "good" ambush site. The attack element is deployed in the formation best suited to the overall situation (Figure C-18).

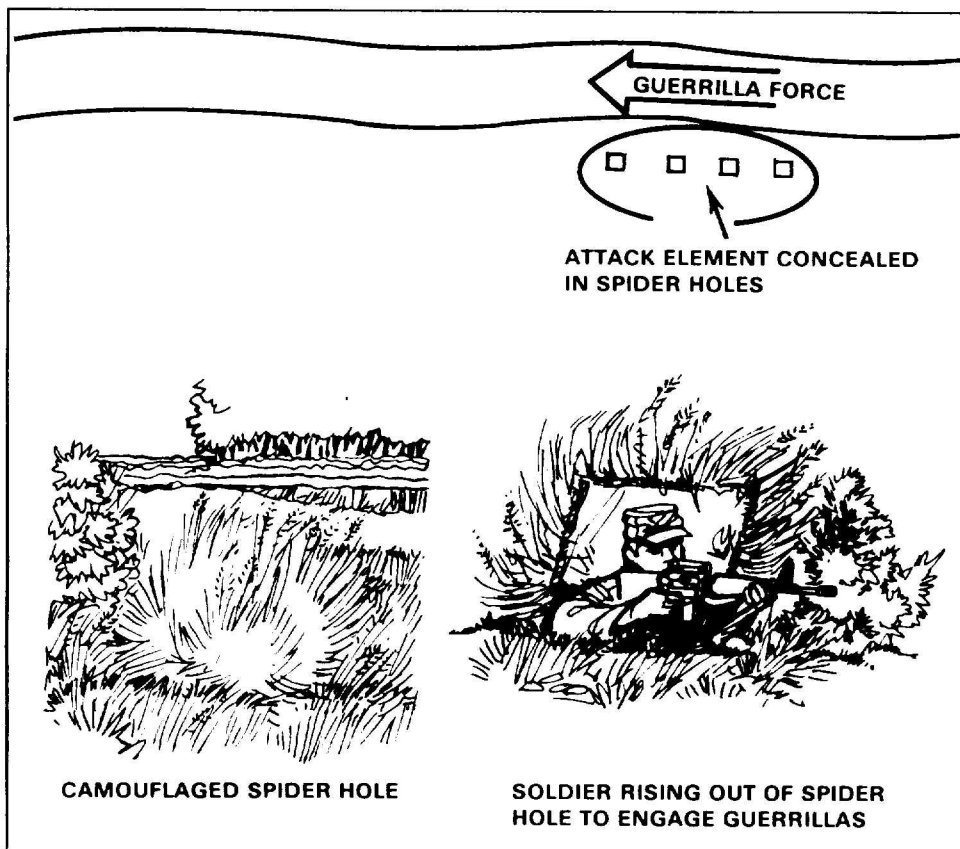

Figure C-18. Spider hole ambush.

- b. The attack element is concealed in the "spider hole" type of covered foxhole. Soil is carefully removed and positions expertly camouflaged.
- c. When the ambush is initiated, the attack element members throw back the covers and literally "rise from the ground" to attack.
- d. This ambush takes advantage of the tendency of patrols, and other units, to relax in areas that do not appear to favor ambush.
- e. The chief disadvantage is that the ambush element is vulnerable if detected prematurely.

C-26. Demolition ambush.

- a. Dual primed, electrically detonated mines or demolition charges are planted in an area over which a guerrilla force is expected to pass. This may be a portion of a road or trail, an open field, or any area that can be observed from a distance. Activating wires are run to a concealed observation point sufficiently distant to ensure safety of the ambush element.
- b. As large a force as desired or necessary can be used to mine the area. The ambush element remains to fire the charges; other personnel return to the unit.
- c. When a guerrilla force enters the mined area (kill zone), the element on site detonates the explosives and withdraws immediately to avoid detection and pursuit (Figure C-19).

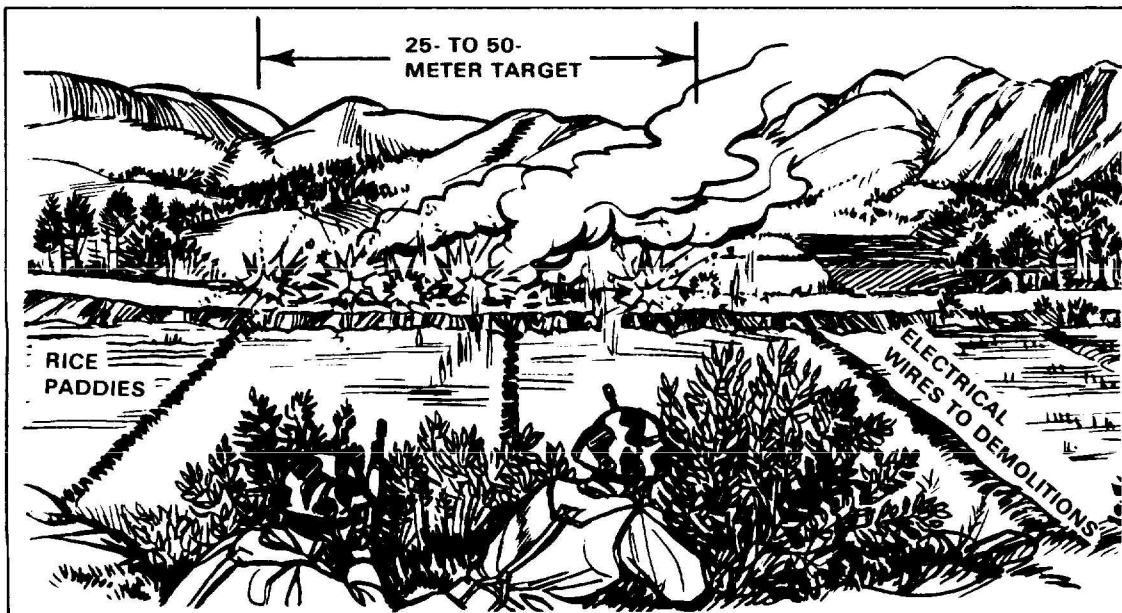

Figure C-19. Demolition ambush.

C-27. Special ambush situation.

Attacks against columns protected by armored vehicles depend on the type and location of armored vehicles in a column, and the weapons of the ambush force. If possible, armored vehicles are destroyed or disabled by fire of antitank weapons, landmines, and Molotov cocktails, or by throwing hand grenades into open hatches. An effort is made to immobilize armored vehicles at a point where they are unable to give protection to the rest of the convoy and where they will block the route of other supporting vehicles.